

**BAT/IS-system
for
Pore pressure measurement**

BAT®

BAT Geosystems AB
Box 1060
SE - 186 26 Vallentuna
Sweden

Phone +46 8 51170600
Fax +46 8 51173361

www.bat-gms.com

ver 2006-11-22

Contents

	Page
System description	1
System components.....	2
Preparation of the BAT/IS-sensor	3
Connection of the BAT/IS-sensor to a BAT MKIII Filter Tip	4
Pore Pressure measurements	5
Downloading and processing of data.....	7
Evaluation of data	8
Maintenance and trouble shooting	9
BAT Pore Pressure Kit	10
Accessories.....	11
APPENDIX 1 Modes of pore pressure measurement.....	12
APPENDIX 2 BAT Pore Pressure Kit	13

System Description

BAT Pore Pressure System

System description

The key components of the BAT Pore Pressure System are:

- BAT MkIII Filter Tip
- BAT/IS-sensor with Battery Unit
- BAT/IS Field Unit

BAT MkIII Filter Tip

The BAT MkIII Filter Tip is connected to an one-inch extension pipe. In soft soils, the filter tip can be installed into the soil simply by pushing it down to the desired depth. In harder soils, predrilling may be required.

Unique quick-connect system

The BAT MkIII Filter Tip is sealed with a flexible septum. A hydraulic connection to the filter tip is made with a hypodermic needle which penetrates the septum. The hypodermic needle and the flexible septum act as a self-sealing, leakproof quick-coupling.

BAT IS Sensor

The BAT IS Sensor functions both as a pressure sensor and logger in one unit. The sensor is powered with a standard battery, housed in a Battery Unit. At its nose the sensor is equipped with a hypodermic needle. When lowered down the extension pipe the sensor will make a leakproof, hydraulic connection with the BAT MkIII Filter Tip, simply by penetration of the hypodermic needle through the flexible septum in the filter tip.

BAT IS Field Unit

The BAT IS Field Unit has been specially designed to operate together with the BAT/IS Sensor.

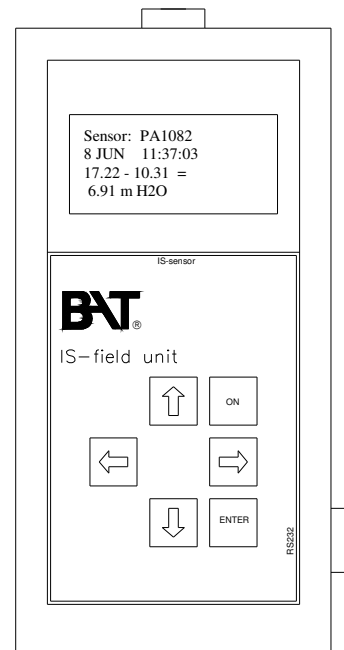
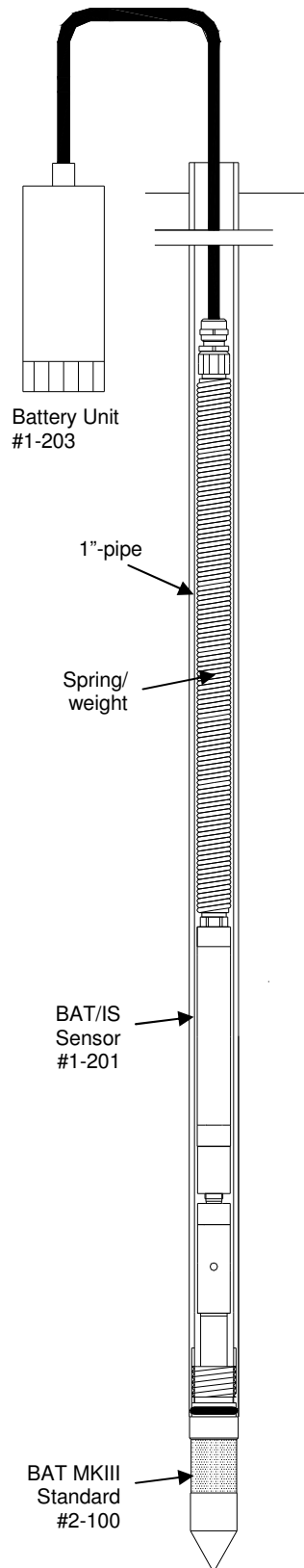

BAT/IS Field Unit #1-300

System Components



Preparation of the BAT/IS-sensor

The BAT/IS pressure sensor consists of the components shown in figure 1a. At delivery most components are already assembled.

Remember to only hand-tighten all components!

- Check the O-ring (6,35*1,78 mm) on the transfer nipple.
- Gently attach a single-ended needle (blue) on the transfer nipple by holding the plastic needle package.
- Screw the guide sleeve onto the transfer nipple.
- Check the O-ring (12,7*1,6 mm) and the plexiglass adapter for any defects. Replace if necessary. Screw the plexiglass adapter onto the BAT/IS Sensor. Hand tighten only!
- Use the syringe to fill the space in the plexiglass adapter with de-aired fluid, see figure 1b. If there is no risk of freezing, water may be used. Otherwise an antifreeze solution shall be used as described in figure 1b below.
- Screw the transfer nipple into the plexiglass adapter only until the O-ring seals inside the adapter (figure 1c). Make sure that a few drops of water bleed through the needle. Between individual measurements, the bleeding through the needle shall be repeated by gradually screwing the transfer nipple into the plexiglass adapter. The transfer nipple can be screwed five full turns until it seats onto the plexiglass adapter. Unscrew the transfer nipple and repeat the procedure described above.
- Tap the pressure sensor gently to bring eventually trapped air bubbles to the top. Remove the air bubbles by screwing the transfer nipple further into the plexiglass adapter.

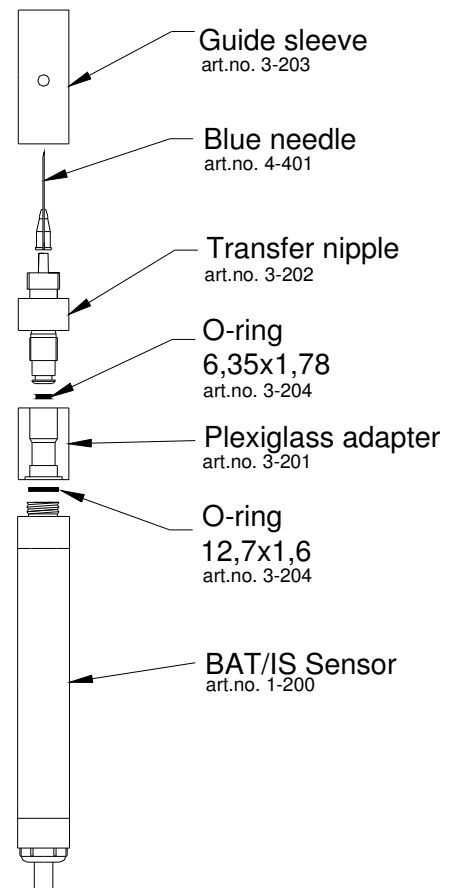

Figure 1a. The BAT/IS-sensor and its components.

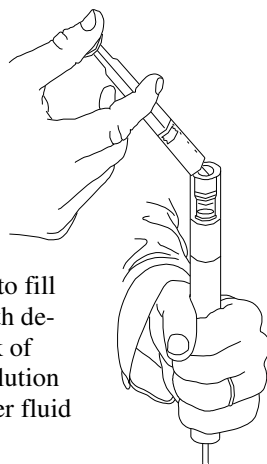

Figure 1b. Use a syringe to fill the plexiglass adapter with de-aired fluid. In case of risk of freezing, an antifreeze solution of type windscreen washer fluid shall be used.

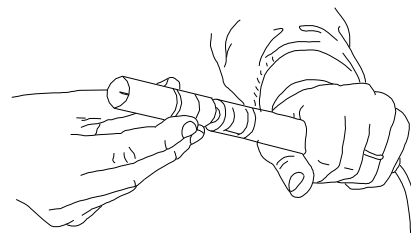

Figure 1c. Bleed the transfer fluid by gently tightening the transfer nipple. Make sure that the O-ring seals inside the plexiglass adapter.

*) Note. The antifreeze solution is to prevent freezing which may damage the membrane.

Connection of the BAT/IS-sensor to a BAT MKIII Filter Tip

- Prepare the BAT/IS-sensor according to figures 1a, 1b and 1c.
- Check the battery in the Battery Unit. Make sure that the battery is in a good condition. It is recommended to use an ordinary 1.5V D-type alkaline battery. In case a prolonged service life of the battery is required, a lithium battery D-type (SAFT LS33600) can also be used.
- Hold a rag around the cable to wipe off any dirt during installation of the BAT/IS sensor. Also check the guide sleeve for any dirt.
- While checking the guide sleeve, make sure that the needle is in perfect condition, if not, have it changed. A bent or broken needle will not just make the readings impossible, in worst case it may damage the filter tip.
- Gently lower the BAT/IS-sensor down the extension pipe. Don't push or force the sensor down the pipe! The BAT/IS-sensor will connect to the BAT MKIII Filter Tip simply by gravity. For a proper function, make sure that the sensor is lowered very slowly the last meter until connection with the filter tip.

When the sensor reaches the filter tip, the needle will penetrate the septum in the filter tip and connect to the fluid inside the tip. This connection can be observed on the BAT/IS Field Unit as a sudden pressure change.

After the sensor has been connected to the filter tip it will take some time to allow the reading to stabilize.

In highly permeable soils a stabilised reading can normally be taken after only one minute, whereas in impermeable clay soils it may require some 5-10 minutes for the reading to stabilize. The change of measured pressure is partly due to time needed for temperature equalisation between the sensor and the interior of the extension pipe.

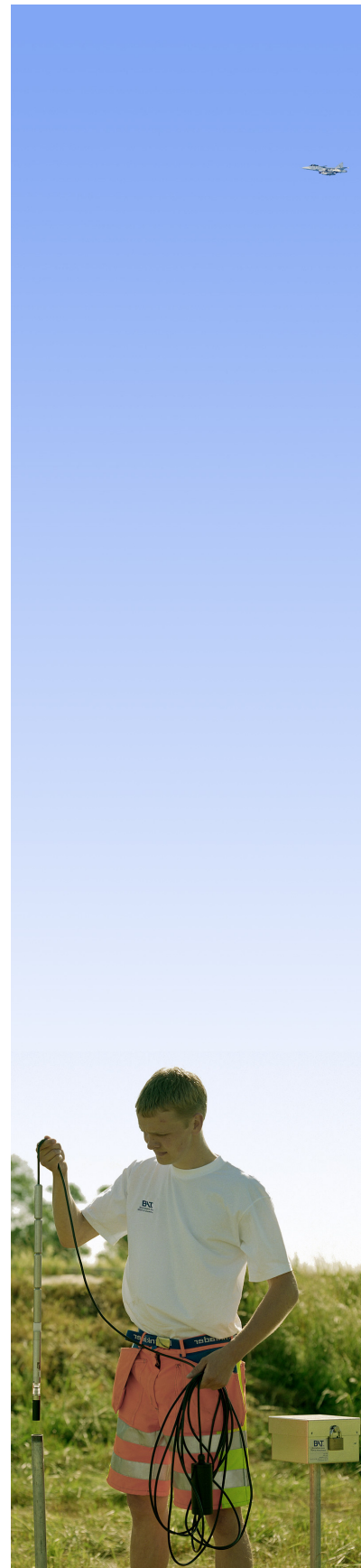

Pore Pressure measurements

General

Due to the quick connect system, the BAT Piezometer can be used in a highly flexible manner, as described in APPENDIX 1. The different modes of pore pressure measurements are: (i) single manual measurement; (ii) automatic stand-alone logging; (iii) IS-network stand-alone data logging; (iv) GSM option for wireless data transfer.

IS Field Unit

The BAT/IS Field Unit is designed especially for use with the BAT/IS-sensor. The Field Unit is equipped with an internal atmospheric pressure sensor for automatic compensation of the absolute pressure readings taken by the BAT/IS-sensor.

Prior to starting long term measurements always check the batteries. Connect the cable between the top socket on the Field Unit to the sensor Battery Unit. Thereafter press the ON-button and after a few seconds the following menu will appear:

>IS Sensor <
IS-GSM Module
Field Unit

Use the **↑** and **↓** keys to choose between the menu options. To check the sensors battery, highlight the IS Sensor option and press the ENTER-key. A new menu will appear and here you select the Sensor Status option. Now the display shows both the remaining memory and the sensors battery status. By choosing the Field Unit option the memory and battery status of the Field Unit will be displayed.



In several options of the submenus, numbers can be entered and/or different options selected. Since the IS Field Unit is not equipped with a numeric keypad, the numbers have to be entered using the arrow keys. With the **↑** and **↓** key you increase or decrease the number. With the **➡** key you select the digit at the right side of the current selected and with the **⬅** key you select the digit at the left side of the current digit selected. The selected digit will flash on the screen of the IS Field Unit.

Due to screen size, the information in some menus is not immediately visible. Use the arrow keys to scroll.

Choose Switch Off in the main menu to turn the Field Unit off.

Please note: if you are in the main menu or a submenu, and if you do not press any key for five minutes, the IS Field Unit will switch off automatically in order to save batteries.

Pore Pressure measurements

Manual measurement (Display function)

1) Connect the IS Field Unit to the sensor and switch it on. Choose IS Data Logger in the main menu and press ENTER. Select with the arrow keys the option Display. The IS Field Unit automatically searches for the BAT/IS-sensor and displays the actual measured pressure (U_m), serial number of the sensor, date and time. In the screen is also displayed the measured atmospheric pressure (p_{atm}) by the Unit Sensor which allows the calculation of the relative pressure (u_m), also displayed on the screen. Always remember that the BAT/IS-sensor measures the absolute pressure.

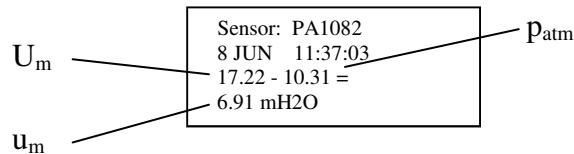

2) Connect the BAT/IS-sensor to the **filter** tip.

3) After connection to the BAT Filter Tip, wait a few minutes to allow the reading to stabilize. Note the measured value of the relative pressure including sensor number, date and time. The pressure measurement will automatically be updated every third second.

4) Press ENTER to leave the Display menu. To change the units displayed, use the left and right arrows to toggle between the unit options.

Automatic stand-alone data logging (Logger function)

1) Before starting a continuous measurement, **check the batteries and available memory** of the BAT/IS-sensor. If necessary, clear the memory in the sensor (this procedure is described below).

2) Select Start Measure in the IS Data Logger menu. Use the arrow keys to choose the measurement settings such as time interval, pressure measurement and/or temperature measurement.

3) Choose OK to start the measurement. To cancel the measurement you simply cancel the menu without starting any measurement.

NOTE! (i) Manual (real time) measurement can also be performed during automatic logging without any interferences.

(ii) To turn off the logger mode *during storage* of the sensor you have to remove the sensor battery.

Measuring atmospheric pressure with the Unit sensor

The IS Field Unit is equipped with an atmospheric pressure sensor, “Unit Sensor”, which easily allows you to compensate for variations in air pressure (**N.B.** When making manual measurements of pore pressures, compensation for the atmospheric pressure is automatically made - see above). You can either measure manually using the Display function or in a logger mode. At delivery, to save battery, the Unit Sensor is deactivated.

To measure manually you turn on the IS Field Unit and choose Unit Sensor in the main menu. Use the arrow keys to select Display and press ENTER. Press ENTER again to leave the Display menu.

Choose Start Measure in the Unit Sensor menu to measure the atmospheric pressure in a logger mode with the Unit Sensor. The measurement settings can now be changed. By checking the Clear Data box, the data in the memory of the sensor will be erased at the start of a new measurement. Choose OK to start the measurement. The measurement will continue also when the IS Field Unit switches off or has been switched off.

- The sensor can store an amount of 3500 measurements. (3500 pressure readings or 3500 temperature readings or alternatively 1750 pressure +1750 temperature readings)
- The service time of a D-size alkaline battery is ~4 months and for a D-size lithium battery ~8 months, respectively.

Downloading and processing of data

Downloading data

To download the measured data from the BAT/IS-sensor to the IS Field Unit, you select the option Download Data in the menu IS Data Logger. Press ENTER and the IS Field Unit will automatically read out and store the data. To abort downloading, press ENTER again.

The downloaded data will be kept in the memory of the IS Field Unit. Downloaded data can be viewed with the option Show Data in the same menu. Downloading data will not affect ongoing measurements by the BAT/IS-sensor.

Note! The memory in the BAT/IS-sensor will not be erased when downloading. The memory is cleared only if you select Clear Data in the Start Measure menu.

PC Processing

Software installation

Firstly, you have to install the included IS-software on your Windows compatible computer. Insert the CD and select the setup-program in the Logger4 folder. The installation wizard will guide you through the installation process.

Download measured data to the PC

Use the same cable as for the connection between the sensor and the IS Field Unit. Place one cable end in the COM-port (or USB-converter) of your computer. Attach the other cable end in the RS232 connector of the IS Field Unit. **NB. The BAT/IS Field Unit shall be switched off.**

Start the program *Data Logger* in the *Profound* menu in your PC or laptop. If not found you can execute the program from its directory. Select the option *Load Data* in the *Field Unit* menu.

The PC automatically downloads all the data from the memory of the IS Field Unit. The program will cascade the downloaded files. Each data file gets automatically a name containing sensor-number and time for download. For example the filename "PA1013 20051018 1145.is" tells that the data in the file was downloaded from the sensor PA1013 the 18th of October 2005, 11:45am.

To transfer the data to an Excel worksheet, you simply select the ASCII-format (*.csv) when saving the file. When opening the file from Excel, an import wizard will appear that guides you to through the import process.

The downloading process of pressure readings of the Unit Sensor is the same as for downloading BAT/IS-sensor data with the exception that you select *Load Data* in the *Logger* menu.

To view the data in the memory of the IS Field Unit you go to the option Show Data in the Field Unit or IS Data Logger menu. The memory in the IS Field Unit has the capacity of storing measurement data from 32 full BAT/IS-sensors.

Note! The memory in the IS Field Unit will not be erased when transferring downloaded data. The memory is cleared only if selecting Erase Data in the Field Unit menu.

Evaluation of data

Note. The unit of pressure measurements in the imported file is in Pascal (Pa). The BAT/IS-sensors are absolute pressure sensors and therefore also record the variations in the surrounding atmospheric pressure. These pressure variations can be accurately compensated for if you conduct simultaneous measurements of the atmospheric pressure in the area.

You can use the built-in Unit Sensor in the IS Field Unit for measurement/logging of the atmospheric pressure, or alternatively use an extra BAT/IS-sensor for the logging of only atmospheric pressure.

The Field Unit displays both the existing, absolute pore pressure U_m , the atmospheric pressure, p_{atm} and the measured relative pore pressure, u_m . The relative pore pressure, u , at the elevation of the filter is calculated as follows:

$$u = U_m - p_{atm} + 0,2 = u_m + 0,2 \quad (\text{m H}_2\text{O})$$

or

$$u = U_m - p_{atm} = u_m + 2 \quad (\text{kPa})$$

where:

- u = relative pore pressure at filter elevation
- u_m = measured relative pore pressure
- U_m = measured absolute pore pressure
- p_{atm} = measured atmospheric pressure

Note!
Due to head differences between the pressure membrane in the BAT/IS-sensor and the center of the filter tip you have to **add 2 kPa (or 0,2 m H₂O)** to the measured value in order to get correct value of the actual pore pressure.

U_m
(absolute pressure)

u_m
(relative pressure)

Sensor: PA1082
 8 JUN 11:37:03
 17.22 - 10.31 =
 6.91 m H2O

□

IS-sensor

 IS-field unit

↑

ON

←

→

↓

ENTER

RS232

p_{atm}
(atmospheric pressure)

Pressure Units

kPa	m H ₂ O	bar	atm
1	0,102		
9,81 (= g)	1		
100	10,2	1	
101,3	10,33		1

Maintenance and trouble shooting

In order to guarantee the accurate and trouble-free operation of the BAT-system you need to follow these maintenance instructions.

- Visually inspect all parts in the BAT-system for any defects (e.g. cables, batteries, sockets)
- The electronics are sensitive for moist. Thus, after use in moist or cold conditions, let the equipment dry out indoors. Keep the lid of the pore pressure kit opened, open the Battery Unit and remove the plastic socket cover of the IS Field unit.
- Keep the IS Field Unit in a dry and safe place.
- Check the cables for breaks. Handle all cables with care if twisted.
- Regularly check all the batteries in the BAT-system. Use only prescribed batteries

In case of errors while measuring with the BAT-system please check this first:

- Is the needle damaged or broken?
- Is the transfer nipple correctly assembled?
- Check the O-rings!
- Is the plexiglass adapter intact?
- Is the plexiglass adapter not properly filled with fluid?

Possible error messages:

Possible errors:

Lost contact with sensor	The field unit can not start the continuous measurement. Check the cable between the field unit and the BAT/IS-sensor and the battery in the Battery Unit.
Communication error!	Probably the sensor cable is broken. Check if this error occurs with another sensor. Also check the 9-pin communication cable.
This sensor has a configuration error	Please contact BAT Geosystems AB. Transferred data shall be handled as faulty until an evaluation proves the opposite.
No sensor connected!	Disconnect the field unit and restart it. Also remove and re-insert the battery in the Battery Unit. Check socket and cable connections. If no success, contact BAT Geosystems AB.

BAT Pore Pressure Kit #1-101

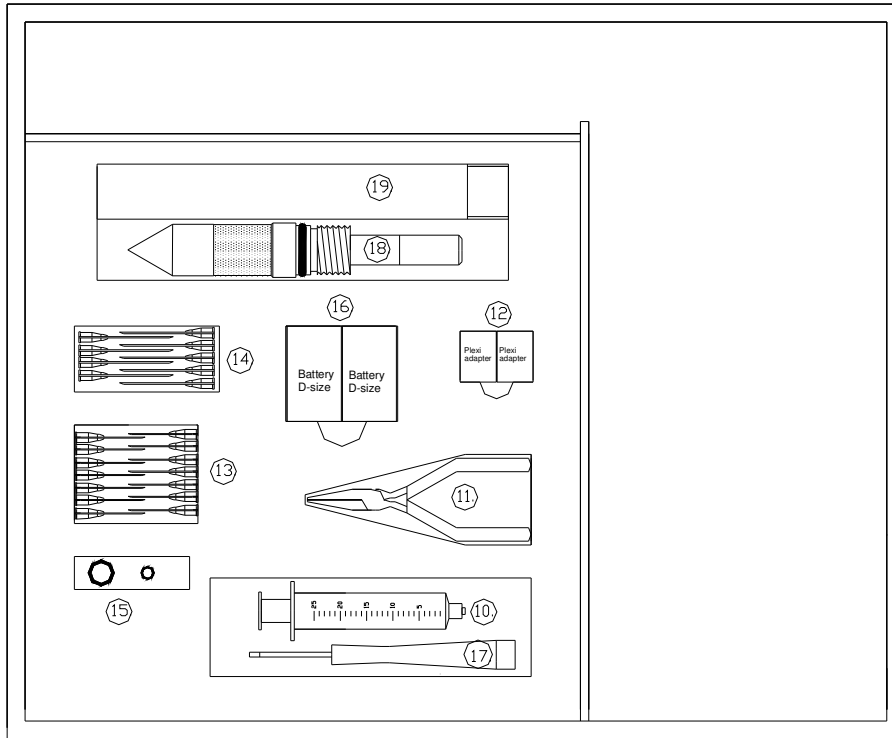

Contents

10) Syringe 25 ml	art.no
11) Pliers	#4-404
12) Plexiglass adapters (2pcs)	#3-206
13) Set of blue needles (20 pcs)	#3-201
14) Set of yellow needles (10 pcs)	#4-401
15) Set of spare O-rings, 12.7x1.6 & 6.35x1.78 mm (5+5 pcs)	#4-402
16) 2 pcs. Spare batteries, D-size	#3-204
17) Screwdriver	-
18) BAT MKIII Filter Tip Standard	#3-209
19) One-inch galvanised adapter pipe	#2-100
	#3-101

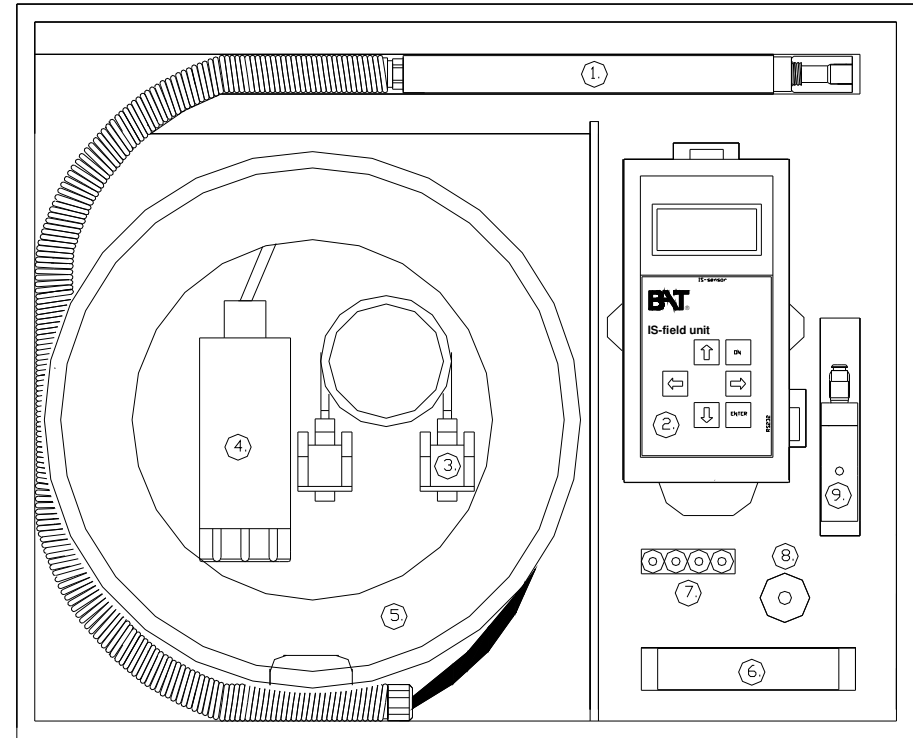

Contents

1) BAT/IS Sensor incl. Accessories & Cable reel (#3-205) and IS-Battery Unit (#1-203)	art.no
2) IS Field Unit	#1-200
3) Communication cable to IS Field Unit	#1-300
4) IS Battery Unit	#3-210
5) Cable Reel	#1-203
6) Centralisation adapter	#3-205
7) 4 pcs. Spare batteries, AA-size	#3-105
8) Container for used needles	-
9) Guide sleeve & transfer nipple	#4-406
	#3-203 & 3-202

Accessories



Protective housing for safe storage of the BAT/IS cable and Battery Unit during logger measurements.
#3-207



Measure tape for accurate determination of installation depth of the filter tip.
#3-106

Filter Tips



BAT MKIII Standard
maximum installation force: 25kN
#2-100 (including 1" galvanized adapter pipe)



BAT MKIII Vadose
for measurement of negative pressures
#2-102 (including 1" galvanized adapter pipe)



BAT MKIII Steel
reusable filter tip made of stainless less. Allows higher installation forces than the Standard filter tip.
#2-101 (excluding stainless steel adapter pipe)
#3-102 1" adapter pipe, stainless steel

BAT Geosystems AB
Box 1060
SE - 186 26 Vallentuna
Sweden

Phone +46 8 51170600
Fax +46 8 51173361

www.bat-gms.com

Due to the unique quick-coupling system, the BAT Piezometer can be used in a highly flexible manner.

The different modes of pore pressure measurement are:

Single manual measurement

The traditional BAT Piezometer uses single, manual measurements. This type of measurement can be repeated with maintained accuracy over a long period of time (several years).

One BAT Piezometer can serve several, permanently installed BAT Filter Tips.

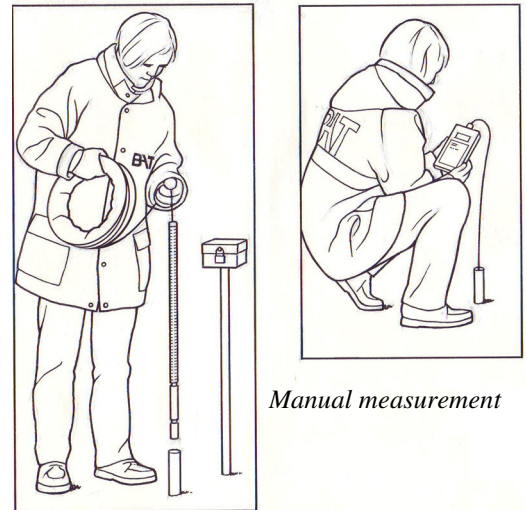

Manual measurement

Automatic stand-alone data logging

The IS Sensor can be programmed in a stand-alone logging mode to take pressure measurements at preselected time intervals. An ordinary alkaline battery, housed in a IS Battery Unit, makes it possible to log data over several months.

It is convenient to place the Battery Unit in a protective casing, attached to the extension pipe.

Automatic stand-alone data logging

IS Battery Unit Protective housing

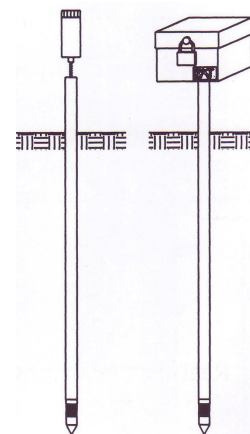

IS-network stand-alone data logging

The fully digital IS Sensors can easily be connected in an IS-network. In the stand-alone version, on single IS Logger Unit can manage the logging of up to ten IS Sensors. Powered with ordinary alkaline batteries the IS Logger Unit can log data over a period of several months.

The IS Logger Unit is equipped with an internal pressure sensor for automatic compensation for variations in atmospheric pressure.

IS-network GSM Option

GSM Option

The IS Logger Unit can be equipped with an IS GSM Module for wireless data transfer. This option enables you to download the logged IS Sensor data where and when you like and also to analyse the the measurement data on your PC.

Powered with ordinary alkaline batteries the GSM Module can log and transmit data for several months.

