

**Pore pressure
measurement with the
BAT Piezometer Basic**

BAT®

BAT Geosystems AB
Box 1060
SE - 186 26 Vallentuna
Sweden

Phone +46 8 51170600
Fax +46 8 51173361

www.bat-gms.com

ver 2006-11-13

Contents

	Page
System description	1
Preparation of the BAT-sensor Basic	2
Connection of the BAT-sensor Basic to a BAT MKIII Filter Tip and Pore Pressure measurements	3
Maintenance and trouble shooting	4
BAT Pore Pressure Kit Basic	5
Accessories	6
APPENDIX1 Pressure Indicator EV-120	7

System Description

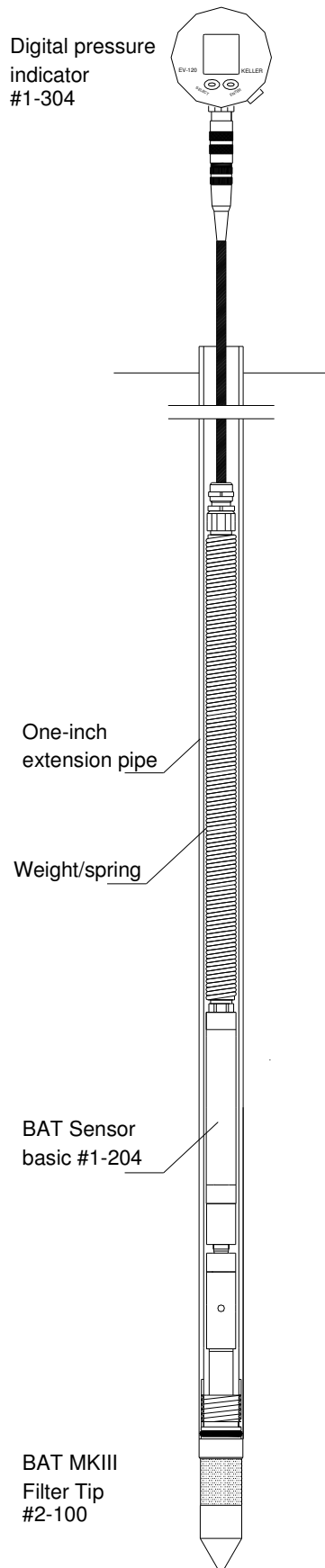

BAT Pore Pressure System Basic

System description

The key components of the BAT Pore Pressure System Basic are:

- BAT MkIII Filter Tip
- BAT-sensor Basic
- Pressure indicator (PI)

BAT MkIII Filter Tip

The BAT MkIII Filter Tip is connected to an one-inch extension pipe. In soft soils, the filter tip can be installed into the soil simply by pushing it down to the desired depth. In harder soils, predrilling may be required.

Unique quick-connect system

The BAT MkIII Filter Tip is sealed with a flexible septum. A hydraulic connection to the filter tip is made with a hypodermic needle which penetrates the septum. The hypodermic needle and the flexible septum act as a self-sealing, leakproof quick-coupling.

BAT Sensor Basic

The BAT Sensor Basic is a real time, vented, pressure transmitter. Its output is a 4-20mA signal which is converted to the chosen pressure unit in the PI. At its nose the sensor is equipped with a hypodermic needle. When lowered down the extension pipe the sensor will make a leakproof, hydraulic connection with the BAT MkIII Filter Tip, simply by penetration of the hypodermic needle through the flexible septum in the filter tip.

Pressure Indicator

The PI converts the sensors analogue output signal to relative pore pressure in kPa or desired unit. It is powered with a 9-volt battery. (See separate manual for more detailed information.)

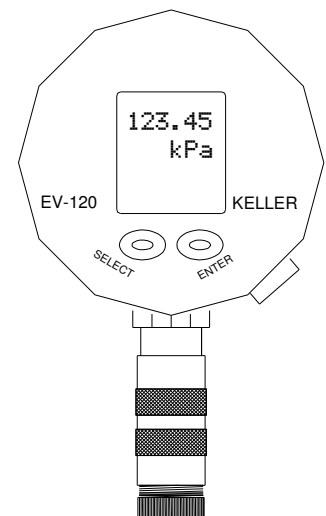

Pressure Indicator #1-304

Preparation of the BAT-sensor Basic

The BAT/IS pressure sensor consists of the components shown in figure 1a. At delivery most components are already assembled.

Remember to only hand-tighten all components!

- Check the O-ring (6,35*1,78 mm) on the transfer nipple.
- Gently attach a single-ended needle (blue) on the transfer nipple by holding the plastic needle package.
- Screw the guide sleeve onto the transfer nipple.
- Check the O-ring (10,82*1,78 mm) and the plexiglass adapter for eventual defects. Replace if necessary. Screw the plexiglass adapter onto the BAT-Sensor Basic. Hand tighten only!
- Use the syringe to fill the space in the plexiglass adapter with de-aired fluid, see figure 1b. If there is no risk of freezing, water may be used. Otherwise an antifreeze solution shall be used as described in figure 1b below.
- Screw the transfer nipple into the plexiglass adapter only until the O-ring seals inside the adapter (figure 1c). Make sure that a few drops of water bleed through the needle. Between individual measurements, the bleeding through the needle shall be repeated by gradually screwing the transfer nipple into the plexiglass adapter.
- Shake the pressure sensor gently to bring eventually trapped air bubbles to the top. Remove the air bubbles by screwing the transfer nipple further into the plexiglass adapter.

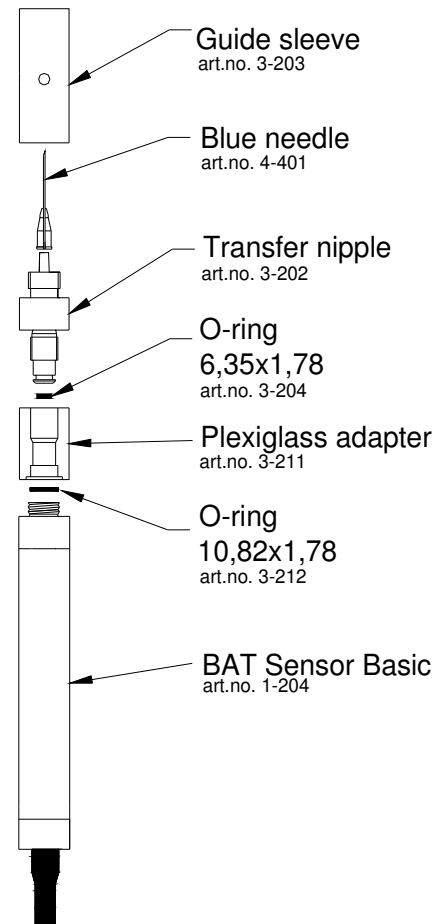

Figure 1a. The BAT-sensor Basic and its components.

*) Note. The antifreeze solution is to prevent freezing which may damage the membrane.

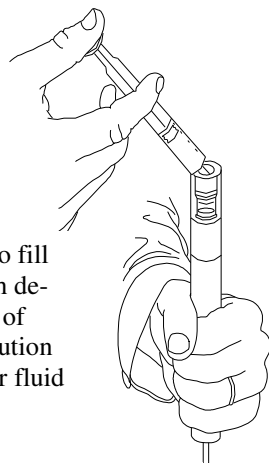

Figure 1b. Use a syringe to fill the plexiglass adapter with de-aired fluid. In case of risk of freezing, an antifreeze solution of type windscreen washer fluid shall be used.

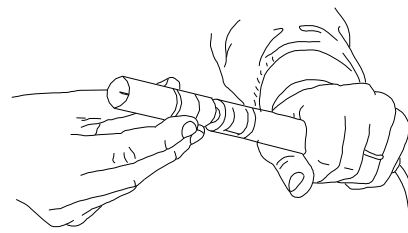

Figure 1c. Bleed the transfer fluid by gently tightening the transfer nipple. Make sure that the O-ring seals inside the plexiglass adapter.

Connection of the BAT-sensor Basic to a BAT MKIII Filter Tip and pore pressure measurement

- Prepare the BAT-sensor Basic according to figures 1a, 1b and 1c.
- Hold a rag around the cable to wipe off eventual dirt during installation of the BAT-sensor Basic. Also check the guide sleeve for eventual dirt.
- While checking the guide sleeve, make sure that the needle is in perfect condition, if not, have it changed. A bent or broken needle will not just make the readings impossible, in worst case it may damage the filter tip.
- Gently lower the BAT-sensor Basic down the extension pipe. Don't push or force the sensor down the pipe! The BAT-sensor Basic will connect to the BAT MKIII Filter Tip simply by gravity. For a proper function, make sure that the sensor is lowered very slowly the last meter until connection with the filter tip.

When the sensor reaches the filter tip, the needle will penetrate the septum in the filter tip and connect to the fluid inside the tip. This connection can be observed on the Field Unit as a sudden pressure change.

After the sensor has been connected to the filter tip it will take some time to allow the reading to stabilise. In highly permeable soils a stabilised reading can normally be taken after only one minute, whereas in impermeable clay soils it may require some 5-10 minutes for the reading to stabilize. Pressure fluctuation is partly due to time needed for temperature equalization between the sensor and the interior of the extension pipe.

Dissipation of pore pressures

When the BAT Filter Tip is pushed into the soil pore pressures will be generated due to the disturbance of the soil. In soft clays, normally high excess pore pressures are generated. On the contrary, in silts and fine sands it can happen that the installation of the filter tip generates a negative pore pressure response due to dilatancy effects in these types of soil. The time needed for dissipation of these disturbance effects on the original pore pressure situation varies with the type of soil. In soft, high plastic clay it may take up to 7 days until the original pore pressure situation is restored. In silts and sands on the other hand, the dissipation of the disturbance effects is much quicker.

Remember to add 0,2 mH₂O or 2 kPa. This addition is due to the head difference between the filter and the pressure membrane on the sensor.

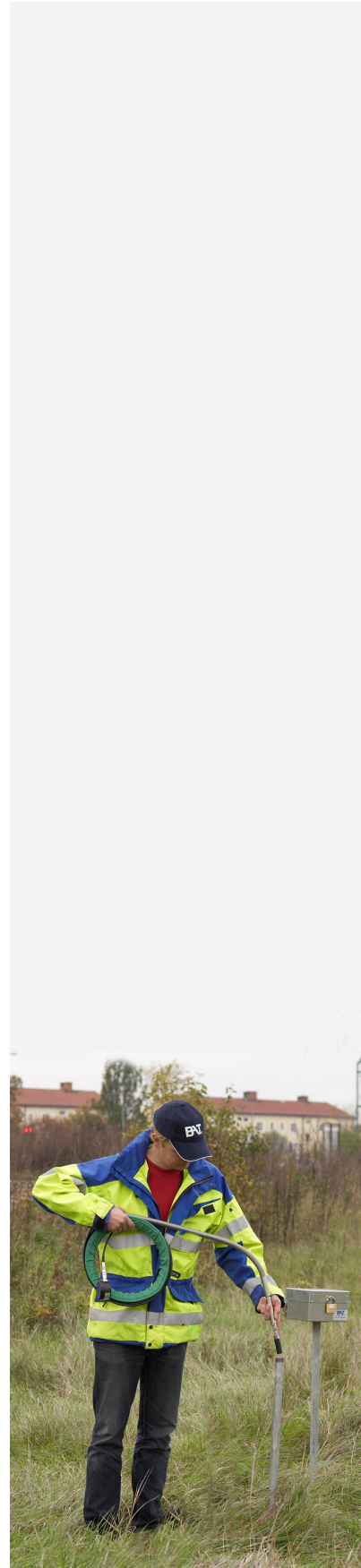

Maintenance and trouble shooting

In order to guarantee the accurate and trouble-free operation of the BAT-system you need to follow these maintenance instructions.

- Visually inspect all parts in the BAT-system for defects (e.g. cables, batteries)
- The electronics are sensitive for moist. Thus, after use in moist or cold conditions, let the equipment dry out indoors.
- Keep the Field Unit in a dry and safe place.
- Check the cables for breaks. Handle all cables with care if twisted.
- Regularly check all the batteries in the BAT-system. Use only prescribed Batteries. The Field Unit battery is placed under the display. Remove the lid, unscrew the battery mounting and change battery if necessary. See APPENDIX1 for more details.

In case of errors while measuring with the BAT-system please check this first:

- Is the needle damaged or broken?
- Is the transfer nipple correctly assembled?
- Check the O-rings!
- Is the plexiglass adapter intact?
- Is the plexiglass adapter not properly filled with fluid?
- Is the ventilated hose intact?

BAT Pore Pressure Kit Basic #1-102

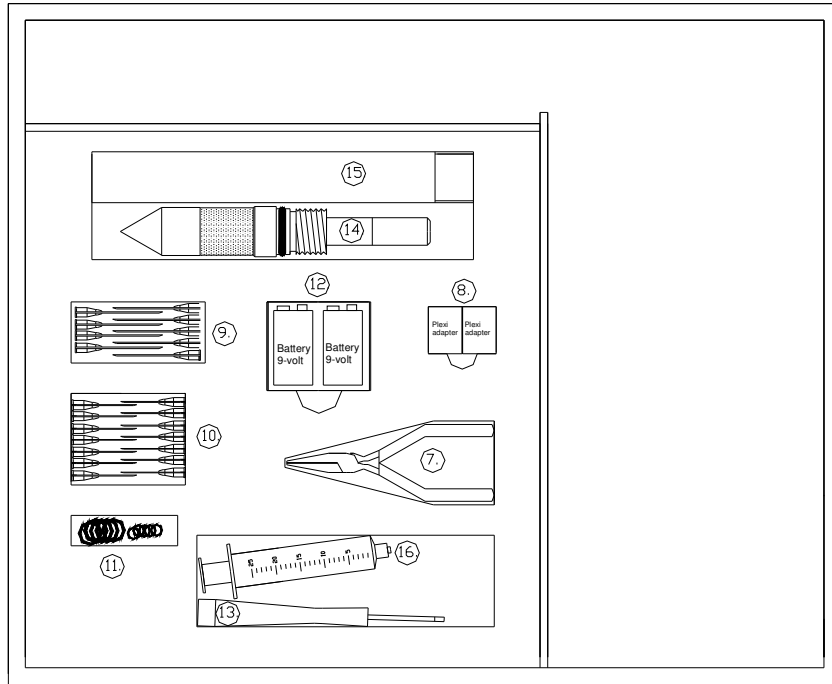

Contents

7) Pliers	#3-206
8) Plexiglass adapters (2pcs)	#-3-211
9) Set of yellow needles (10 pcs)	#4-402
10) Set of blue needles (10 pcs)	#4-401
11) Set of spare O-rings, 10.82x1.78 & 6.35x1.78 mm (5+5 pcs)	#3-212
12) 2 pcs. Spare batteries, 9-volt	-
13) Screwdriver	-
14) BAT MKIII Filter Tip Standard	#2-100
15) One-inch galvanised adapter pipe	#3-101
16) Syringe, 25 ml	#4-404

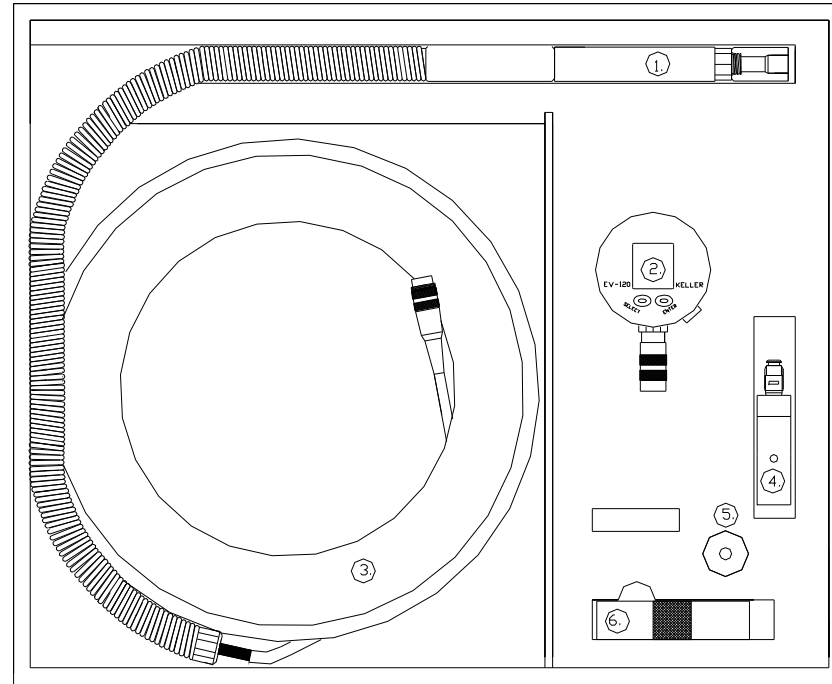

Contents

1) BAT-Sensor Basic incl. Accessories	#1-204
2) Pressure Indicator	#1-304
3) Cable Reel	#3-205
4) Guide sleeve and transfer nipple	#3-203 & 3-202
5) Container for used needles	#4-406
6) Centralisation adapter	#3-105

Accessories



Measure tape for accurate determination of installation depth of the filter tip.

#3-106

Filter Tips



BAT MKIII Standard
maximum installation force: 25kN
#2-100 (including 1" adapter pipe)



BAT MKIII Vadose
for measurement of negative pressures
#2-102 (including 1" adapter pipe)



BAT MKIII Steel
reusable filter tip made of stainless less. Allows higher installation forces than the Standard filter tip.
#2-101 (excluding stainless steel adapter pipe)
#3-102 1" adapter pipe, stainless

BAT Geosystems AB
Box 1060
SE - 186 26 Vallentuna
Sweden

Phone +46 8 51170600
Fax +46 8 51173361

www.bat-gms.com

Pressure Indicator EV-120 (Keller), art.nr. 1-304.

General

The Pressure Indicator EV-120 is especially designed to be used together with BAT Sensor basic, art.nr, 1-204.

"Turn on/turn off"

The Pressure Indicator is turned on by pressing one of the two front keys.

After turn on the instrument displays information about software version and calibrated minimum and maximum pressures in bar.

Execution of commands

Various commands can be executed by using the "select"-key together with the "enter"-key.

When keeping the "select"-key depressed the following command structure will appear in the display:

Command structure: OFF ► rE5 ► 5Et ► cont off ► cont on

OFF	turns off the instrument (press "enter" to turn off)
rE5/5Et	These functions change the zero setting of the instrument. The new zero is permanently stored in the instrument.
rE5	Resets the zero to factory setting.
5Et	Sets a new actual zero..
cont off	Activates the "auto-power-down" function. The instrument automatically turns off 5 minutes after the last operation.
cont on	Inactivates the "auto-power-down" function. "OFF" starts flashing in the display.

Selection of pressure unit

The above command structure is followed by a meny for selection of pressure unit:

bar ► hPa(mbar) ► kPa ► MPa ► PSI ► kp/cm^2

N.B.! In case the actual pressure exceeds the calibrated pressure range the display will show OFL ("overflow").

Recommended settings of the Pressure Indicator

When used together with BAT Sensor basic the following settings of the Pressure Indicator are recommended:

- zero: rE5 , i.e. the factory zero setting
- pressure unit: kPa, the pressure will be displayed with two decimals
- cont off: i.e. activate the "auto-down-power" function in order to save battery

Battery change

The Pressure Indicator is fed by an internal 9V battery. If the display starts to fade or if communication errors occur, it's an indication that the battery charge is weakening. It is recommended to change the battery now. .

Carefully turn the battery cover 10 degrees and detach it from the the main housing. Detach the battery from its mounting and replace it with a new one. Carefully replace the instrument cover.

