



BNT®

Groundwater
Monitoring
System

BAT GMS

the innovative technology for groundwater monitoring and testing

Unique and proven BAT technology

The patented BAT GMS – BAT Groundwater Monitoring System – represents an innovative and proven technology for groundwater monitoring and testing. For more than twenty years the BAT GMS has been successfully used in a great number of groundwater monitoring projects worldwide.

The new generation of BAT GMS

Based on the patented BAT technology, a new generation of BAT GMS has been developed. Key components of this new generation are the BAT MkIII Filter Tip and the BAT IS System (IS = Intelligent Sensor).

The BAT IS-sensor is both a pressure sensor and a logger in one unit. The BAT IS-sensor can also be equipped with a GSM module for wireless data transfer.

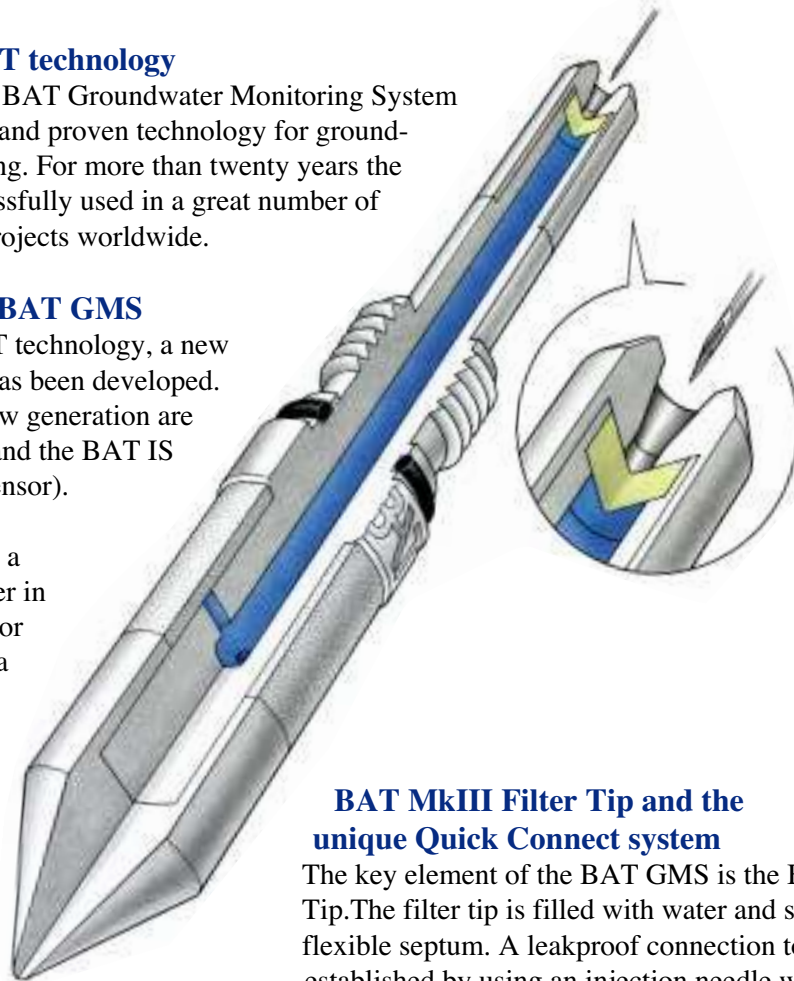

Injection needle & Flexible septum

BAT MkIII Filter Tip and the unique Quick Connect system

The key element of the BAT GMS is the BAT MkIII Filter Tip. The filter tip is filled with water and sealed with a flexible septum. A leakproof connection to the filter tip is established by using an injection needle which penetrates the flexible septum. In other words, the septum and the injection needle form the components of a leakproof quick connect. When the needle is retracted, the septum in the BAT Filter Tip automatically reseals. The septum can be penetrated by the needle hundreds of times without loss of its self-sealing function.

Flexible and cost effective

Due to the patented quick connect system hundreds of installed BAT Filter Tips can be served by only one BAT Measuring/Sampling Kit.

The new generation of BAT GMS can also be used together with the old types of BAT Filter Tips.

Accurate and reliable

Due to the quick connect system, function control of both the various BAT Probes and the installed BAT Filter Tip can be made at any time. When needed, remedial measures can also be undertaken. These features of the BAT system make, for example, possible to conduct longterm pore pressure measurements or discrete sampling of groundwater with a maintained high level of accuracy and reliability.

Multiple functions

The quick connect system of BAT GMS makes possible the interconnection, temporary or permanent, between the BAT Filter Tip and the various BAT Probes such as:

- **BAT Piezometer** for measurement/logging of pore pressures and groundwater levels
- **BAT Permeameter** for in-situ measurement of soil permeability
- **BAT Groundwater Sampler** for collecting discrete samples of groundwater and soil gas

BAT MkIII Filter Tips

Unique design

The BAT MkIII Filter Tip is the key component which gives BAT GMS its unique features. The patented, leakproof quick-connect system makes possible the connection of the various BAT Probes to the BAT MkIII Filter Tip for multiple functions.

Types of filter tips

The range of BAT Filter Tips contains three standard types:

- **BAT MkIII Std.** This filter tip has a body of high-strength thermoplastic and a filter of porous polyethylene.
- **BAT MkIII Vadose.** This filter tip has a body of high-strength thermoplastic and a replaceable ceramic filter, having a high air entry value. This filter tip is designed for installations and measurements in the unsaturated zone.
- **BAT MkIII SS.** This sturdy filter tip has a body of stainless steel and a replaceable filter of porous polyethylene.



BAT MkIII Std



BAT MkIII Vadose



BAT MkIII SS

Installation of filter tips

It is very easy to install the BAT Filter Tip since the tip neither contains any sensitive elements nor is connected to an electrical cable or tubing during installation. The BAT Filter Tips can be installed by use of several methods.

Push –in installation

The most common method is the “push-in” installation. The BAT Filter Tip is connected to an extension pipe, for example an one-inch gas pipe, and is pushed down to the installation depth. This can be made with conventional CPT Units or Drill Rigs. When required, pre-penetration or predrilling can be made through hard and/or coarse soil layers.

Borehole Installation

BAT Filter Tips can also be readily installed using the traditional borehole type of installation. Sealing of the installation can be made either by back-filling with grout or by “grouting-in” the filter tip.

Types of installation

Depending on the specific needs the BAT Filter Tips can be installed in different arrangements such as: single; cluster and “buried/remote” type of installation.

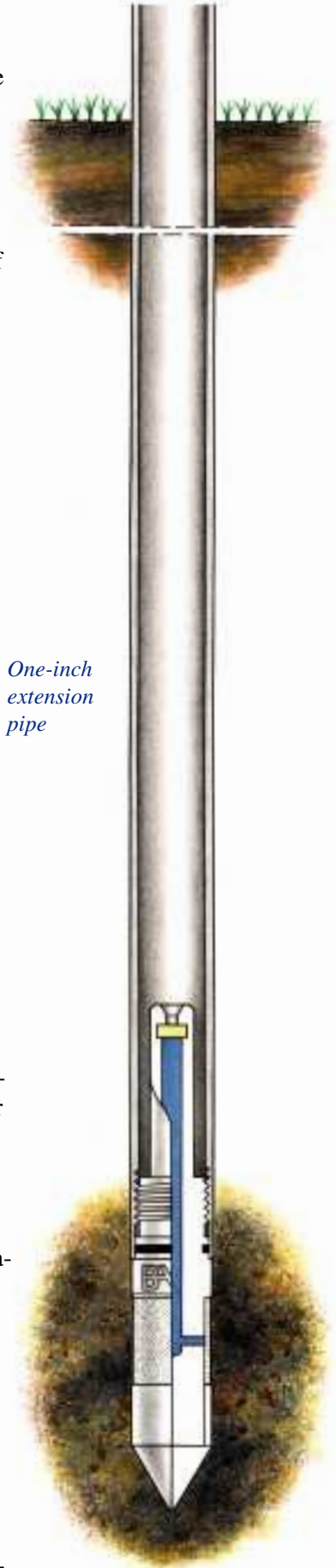

One-inch extension pipe

BAT MkIII Filter Tip

BAT Piezometer for pore pressure measurements

BAT Piezometer is an innovative and proven technology for pore pressure measurements in soils, which has been on the market for more than twenty years. Through the years BAT has gained a lot of experience within the field of pore pressure measurements, which we share with our clients to determine the best instrumentation to meet the specific needs for their projects.

The BAT Piezometer can be used for pore pressure measurements in both the saturated and unsaturated zones of soil. Key features of the BAT Piezometer are high accuracy combined with flexibility and long-term reliability.

BAT IS Sensor - both a pressure sensor and a datalogger

BAT IS Sensor is completely self-contained and features an absolute pressure sensor combined with an AD converter and an internal datalogger.

Without complicated conversion factors this Intelligent Sensor immediately displays the measured pore pressures in the chosen engineering unit. The sensor has also been equipped with a temperature gauge.

Together with a replaceable, ordinary alkaline battery the BAT IS Sensor can collect and store data in a stand-alone mode for about eight months. The IS Sensor can also be inter-connected with other sensors in a fully digital network.

IS Field Unit

The robust IS Field Unit is exceptionally convenient for handling IS Sensor data in the field. This self-contained unit is equipped with a display and keyboard.

Features

- Real-time readings of pressure data in engineering units
- Automatic barometric compensation by use of an internal pressure sensor
- Enables programming of the BAT IS Sensor and also downloading of logged data
- Allows flexible connection to PC for data processing, by using the IS Software



BAT MkIII Filter Tip & pressure measurements

The BAT IS Sensor makes a leakproof connection to the BAT MkIII Filter Tip by the injection needle. For taking a single pressure measurement the IS Sensor is lowered down the extension pipe until it connects to the BAT MkIII Filter Tip. Simply by gravity, the injection needle penetrates the flexible septum in the filter tip. The existing pore pressure is then displayed by the IS Field Unit.

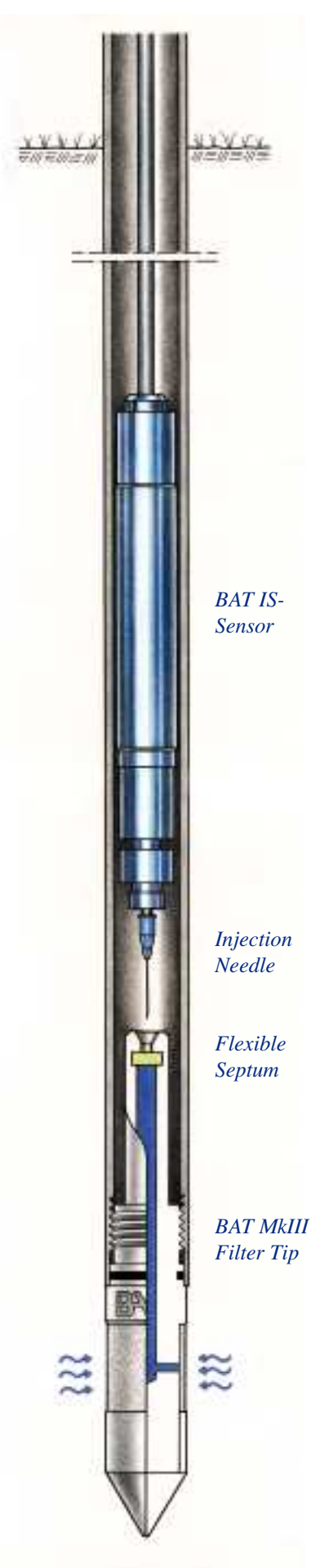

Modes of pore pressure measurement

Due to the unique quick-connect system, the BAT Piezometer can be used in a highly flexible manner.

The different modes of pore pressure measurement are:

Single manual measurement

The traditional BAT Piezometer uses single, manual measurements. This type of measurement can be repeated with maintained accuracy over a long period of time (several years).

One BAT IS Sensor can serve several, permanently, installed BAT Filter Tips.

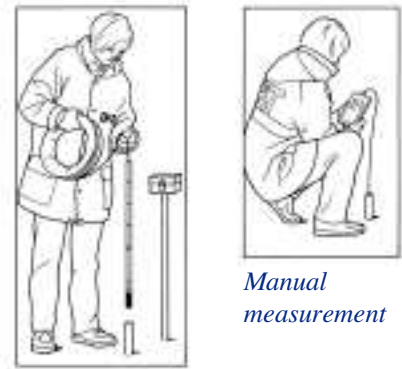

Manual measurement

Automatic – stand-alone data logging

The IS Sensor can be programmed in a stand-alone logging mode to take pressure measurements at preselected time intervals. An ordinary alkaline battery, housed in a IS Battery Holder, makes it possible to log data over several months.

It is convenient to place the Battery Holder in a protective casing, attached to the extension pipe.

IS-network – stand-alone data logging

The fully digital IS Sensors can easily be connected in an IS-network. In the stand-alone version one single IS Logger Unit can manage the logging of up to ten IS Sensors. Powered with ordinary alkaline batteries the IS Logger Unit can log data over a period of several months.

The IS Logger Unit is equipped with an internal pressure sensor for automatic compensation for variations in atmospheric pressure.

Automatic – stand-alone data logging

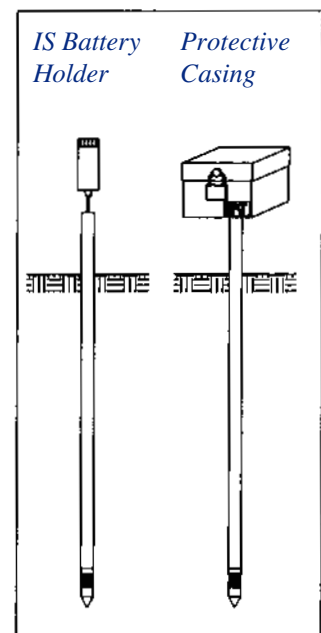

GSM option

The IS Logger Unit can be equipped with a IS GSM Module for wireless data transfer. This option enables you to download the logged IS Sensor data where and when you like and also to analyse the measurement data on your own PC.

Powered with ordinary alkaline batteries the GSM Module can log and transmit data over a period of several months.

IS-network – stand-alone data logging

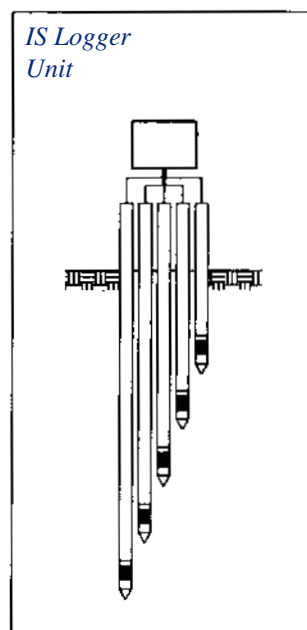

IS-network – GSM Option

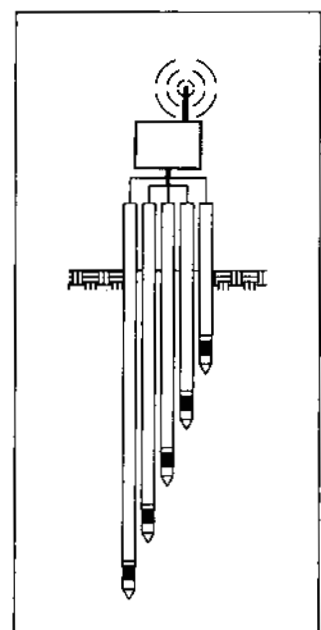

BAT Permeameter

Using the the BAT GMS, in situ hydraulic conductivity tests can be routinely performed, both in unsaturated and saturated soils. The BAT Permeameter combines with the BAT Piezometer equipment and the BAT MkIII Filter tip.

Test assembly

The BAT Permeameter incorporates a Test container. The container is sealed in both ends with a flexible septum.

At its lower end the Test container temporarily interconnects with the BAT MkIII Filter Tip, using a double-ended injection needle. At its upper end the Test container interconnects with the BAT IS pressure sensor, also by using an injection needle. Thus making possible measurement of the pressure, P , inside the Test container.

Conducting a permeability test

The BAT Permeability test is based on measurement of the rate of flow into or out of the Test container. This rate is computed by measuring the pressure change in the Test container, which by using Boyle's law can be translated into a volume change. Analysis of the time-pressure record thus yields the coefficient of permeability, k .

Inflow or outflow tests

The BAT Permeability test can be performed either as an inflow or as an outflow test. The former type of test, starts with an empty Test container, having a lower starting pressure, P_0 , than the equilibrium pore pressure, U_0 , in the tested soil. The outflow test, on the other hand, starts with a partly water filled Test container, having a higher pressure, P_0 , than the equilibrium pore pressure, U_0 .

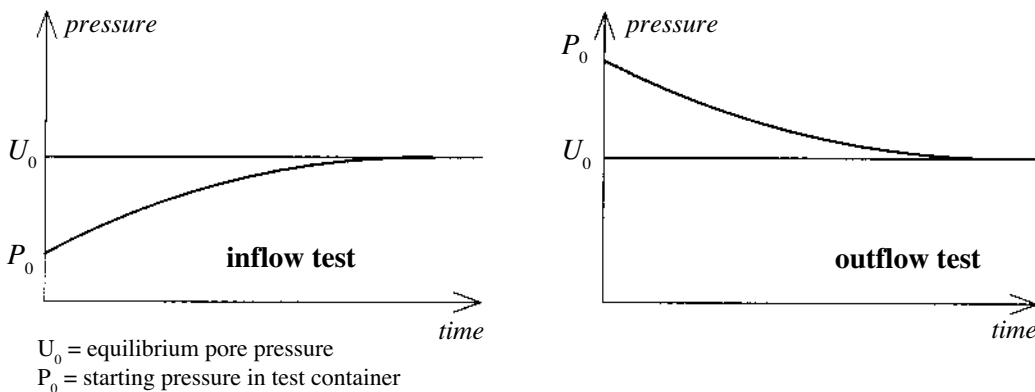

Automatic testing procedure and easy calculation of k – values

By using the logging function of the BAT IS Sensor, pressure data are collected automatically at a preselected time interval.

The time-pressure record can be fed directly into a portable computer for an immediate field calculation of the coefficient of permeability, the k –value.

Applications

Typical in-situ applications for the BAT Permeameter are:

- control of of k -values of compacted clay liners
- control of of k -values of in-situ slurry walls
- checking quality of containment systems at landfills and tailings dams
- checking design parameters for ground improvement systems, such as vertical drains
- general geotechnical investigation



BAT Groundwater sampler

Features

The BAT Groundwater Sampler - EnviroSampler® - is ideal for quick, discrete sampling of both liquid and gas phases at specific depths. All elements of the BAT System, including the encapsulated samples, are hermetically sealed, preventing loss of volatile components. The BAT EnviroSampler® integrates field operations with laboratory techniques.

Components

The BAT EnviroSampler® contains three basic components:

- BAT MkIII Filter Tip, installed at the sampling depth and attached to an extension pipe
- An evacuated sample collection tube
- A double-ended injection needle

Both the filter tip and the sample tube is sealed with a flexible septum.

Applications

Typical applications for the BAT EnviroSampler® are:

- screening of contaminated sites
- long-term monitoring of groundwater and soil gas

Sampling procedure

The sample tube is inserted into a sampler housing which also is equipped with a holder for the double-ended needle. The sampler is lowered down the extension pipe onto the the BAT Filter Tip and simply by gravity the double-ended needle penetrates both the septum in the filter tip and the septum of the sample tube. A temporary leak-proof connection is thus established between the sample tube and BAT Filter Tip.

Due to the action of both the groundwater pressure and the suction in the sample tube, groundwater and/or soil gas will be drawn into the sample tube. Upon lifting the BAT EnviroSampler® the flexible septa in both the filter tip and the sample tube will automatically reseal. The liquid and/or gas sample is thereby kept hermetically sealed all the way from the point of sampling into the laboratory.

Long-term monitoring

The flexible septum in the BAT MkIII Filter Tip can be pierced hundreds of times without loss of its automatic, self-sealing function. This makes possible long-term monitoring of installed BAT Filter tips with a maintained precision and accuracy.

Experience & references

The US-EPA and other high conformance requirement groups have adopted the BAT technology as appropriate and preferred for many environmental characterization applications. The repeatability of the data is cited as one key reason for this reference. BAT technology has also been scrutinized by many other investigators, and has met with widespread acceptance.

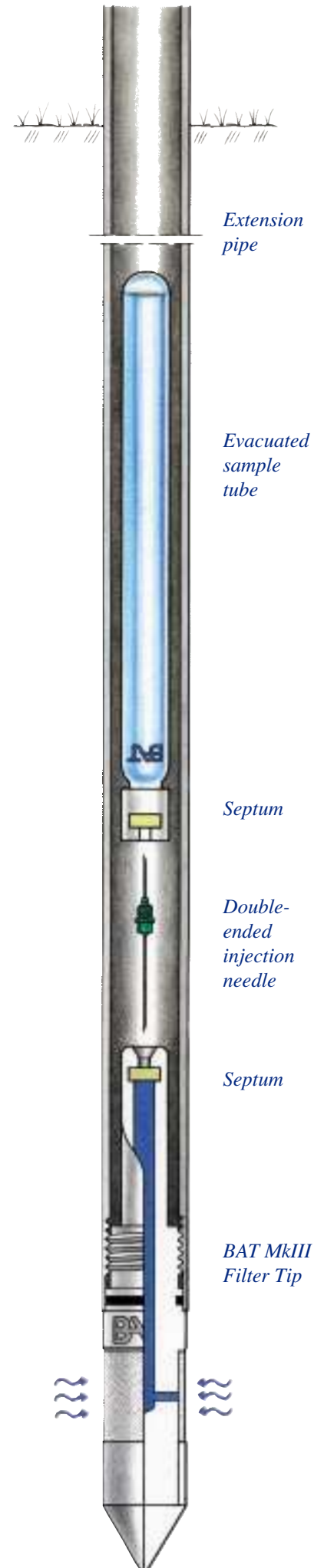

BAT Field Kits

The equipment needed to perform the different functions of the BAT GMS has been arranged in user friendly Field Kits.

BAT Pore pressure kit. Together with the BAT IS Sensor and the IS Field Unit, this kit contains all accessories and spare parts needed for pore pressure measurements in the field.

BAT Permeability kit. This kit contains supplementary equipment which combines with the BAT Pore pressure kit for making in-situ permeability testing.

BAT Groundwater sampling kit. This is a fully self-contained kit for collecting discrete samples of groundwater and/or soil gas from installed BAT MkIII Filter Tips.

Documentation

The different functions of the BAT GMS are described in detail in separate instruction manuals.

In addition, the use of BAT GMS has been documented in a number of technical papers and reports. More details are given at BAT 's web site: www.bat-gms.com.



BAT[®]
www.bat-gms.com

BAT Geosystems AB
P.O. Box 1060
SE-186 26 Vallentuna
Sweden
tel: +468 511 706 00
fax: +468 511 733 61